

ASTRA

VEHICLE TECHNOLOGIES LTD



Installation, Commissioning and Maintenance Instructions

AdInject™
Fuel Borne Catalyst Dosing System
(for application with Adastra Diesel Particulate Filter (DPF) systems)



adinject™

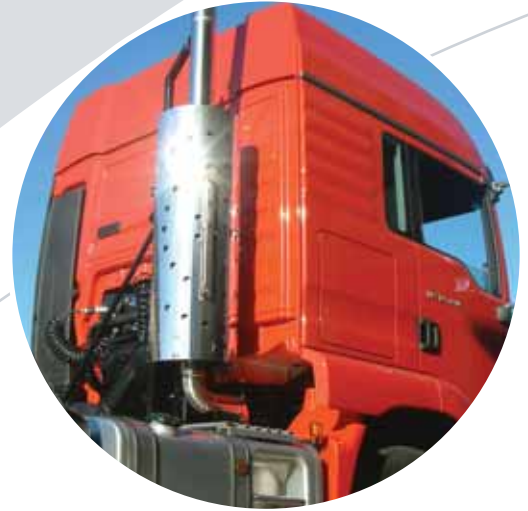

UK VCA approval number: e11*72/245*2006/28*4378*00

e1

03 4378



Contents

- Section 1** Introductory notes
- Section 2** FBC System Overview
- Section 3** FBC System Installation
- Section 4** Active regen – heating system installation
- Section 5** Commissioning
- Section 6** Faults & warning indications
- Section 7** Maintenance

Information for authorised service engineers:

- Section 8** ECU technical specifications
- Section 9** Diagnostics and ECU settings –
via service interface
- Section 10** Hazard data sheet –
Satacen® 3 Fuel Borne Catalyst

Issue 2
Issue Date: August 2007

Section 1 - Introductory notes

1. These instructions should be read before installing an AdInject – In Line fuel borne catalyst dosing system as part of an Adastra filter system installation.
2. Check parts received against the parts list sent with the kit.
3. Please note that the system supplied, is wherever possible designed to be installed on the vehicle with the use of conventional hand tools only. However, due to variations in individual vehicle specifications and accessories, specialist tools may be required.
4. Installation and commissioning of the dosing system electronics should only be conducted by a competent auto electrician.
5. If you are in any doubt about the specification of the system supplied, please seek advice from Astra, or its approved installation contractor.
6. Commissioning and/or adjustments to the AdInject system ECU should only be completed by trained personnel authorised by Astra Vehicle Technologies Ltd. A proprietary service interface cable will be required, together with a laptop computer capable of running a Hyper terminal programme in Windows XP or earlier. Note : Laptops running Windows Vista operating systems may require an additional USB to serial port interface cable and a free download – Hyper terminal programme.

Section 2 - Fuel Borne Catalyst (FBC) injection system overview

The AdInject fuel borne catalyst injection system is designed to be installed in conjunction with an Adastra Diesel Particulate Filter (DPF) system. See separate instructions for DPF installation. The AdInject system comprises an additive tank, injection pump, pipe work fittings; an electronic control unit (ECU) and an associated wiring harness and conduit parts.

The FBC-ECU is designed to perform the following functions:-

- Control the operation of the dosing pump
- Control the operation of auxiliary heating devices
- Monitor fuel borne catalyst level
- Monitor system back pressure
- Output system check and fault conditions to a dashboard located indicator

The Adastra FBC diesel particulate filter system utilises Satacen[®] 3 fuel borne catalyst to aid regeneration of the particulate filter, preventing large accumulations of soot and eventual filter blockage. Injected into the fuel, Satacen[®] 3 aids combustion reducing the total soot burden and ensuring that only catalysed soot enters the filter. Soot pre-catalysed with Satacen[®] 3 will then ignite and combust at significantly lower temperatures than otherwise. A backup "active" regeneration mechanism is also provided in the form of electrical heating devices, which may be brought into operation in the event that the operating duty cycle of the vehicle produces extremely low operating temperatures.

System Installation Diagram.

Fig 1. System Installation Schematic.

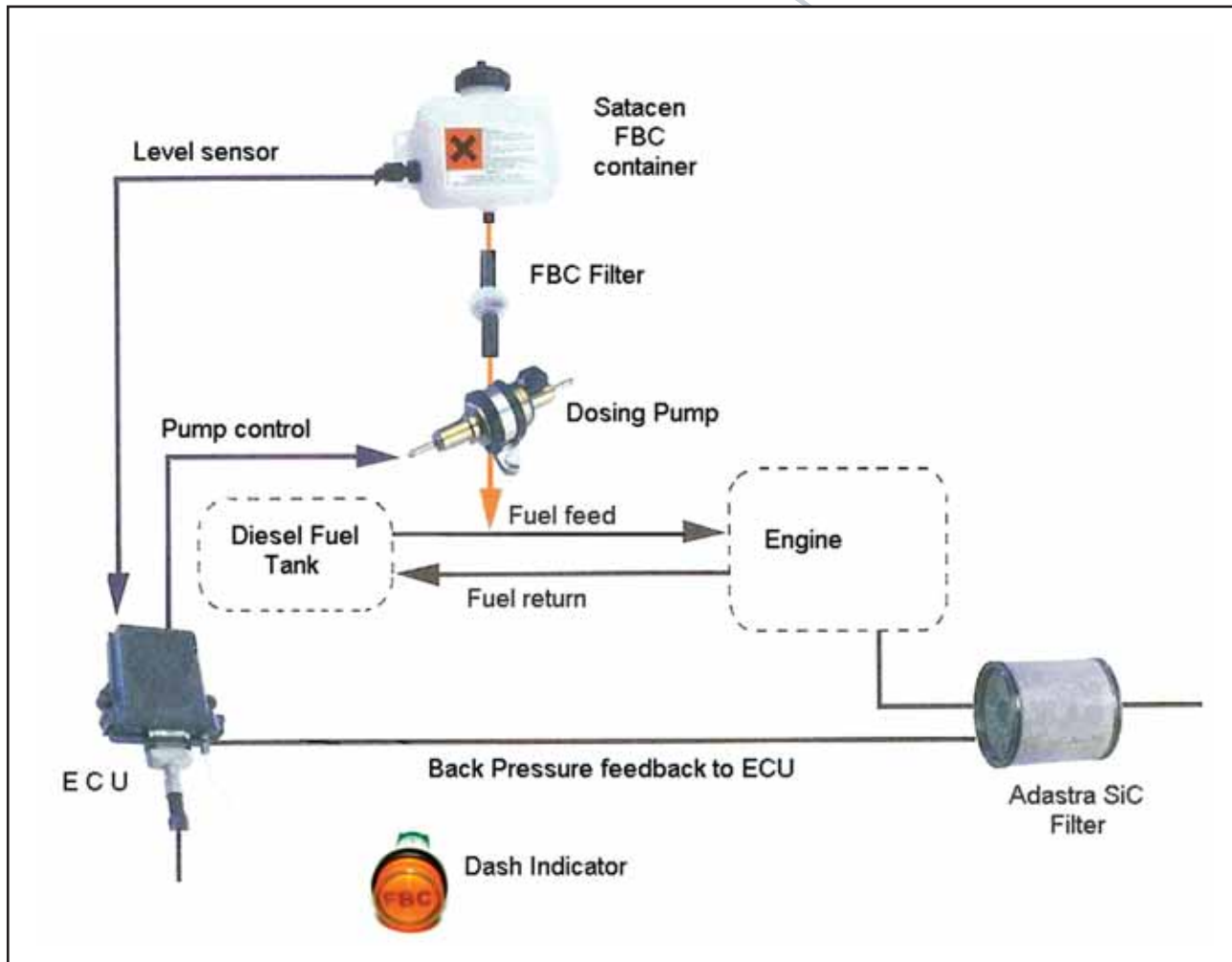

Recommended Fitting Sequence.

1. DPF Exhaust System
2. Additive Tank
3. Solenoid Pump, Fuel Line "T" Piece and Additive Hose
4. ECU & Back Pressure Feedback Hose
5. Wiring Harness Routing
6. Dash Lamp

Section 3 – AdInject™ Dosing System Installation.

3.1 General Guidelines

Installing the system components in the above order ensures optimum routing, lengths of electrical cables and hoses can be achieved.

All wiring and hoses must be securely fastened to the vehicle, paying particular attention to avoid heat sources and potential fouls. **Fuel line "T" piece compression fittings should be ordered separately, as original installations vary in size. Please advise diesel fuel feed line diameter and material type. Push fit connection types should be avoided.**

3.2 Additive Tank.

Install the additive tank using the mounting holes provided, to a vertical plane which provides a flooded suction to the solenoid dosing pump. To assist in selecting the optimum tank location, and in order to provide maximum flexibility, a 3 metre length of additive supply hose (Fig 2. Blue Ø6mm OD – pt no: HS006) is provided within standard kit specifications.

As a general guide, select a location for the additive tank which is as near to the point of injection as possible, but also provides access for service and filling. Where plastic tanks are utilised, a visible line of sight for level checking, is recommended. It is preferable to have a longer suction feed length before the pump and as short an injection line as possible after the pump.

For many systems a custom designed bracket for tank location and mounting may have been designed and supplied with the DPF system kit. Please refer to the drawing and installation instructions accompanying the DPF system.

Additive tanks of various sizes are available from Astra. For commercial vehicles – 2,3 or 5 litre capacity plastic tanks are generally supplied and are complete with mounting points, filler cap (with breather), low level alarm switch (reed type). The accessories are pre-assembled onto the tank such that only the hose and electrical connections are required. Plastic tanks are in natural finish (similar to wash water bottles) where fuel borne catalyst level is clearly visible. A filler /breather screw cap and low level switch are fitted as standard.

All tanks will be supplied with a label advising that only Satacen 3™ Fuel Borne Catalyst should be used when refilling.

3.3 Additive feed hose assembly

As is indicated in Fig 2. – two types of additive supply hose are provided. Please note that for compatibility with Satacen 3™ fuel borne catalyst, use only the grades of hose provided with the AdInject dosing system. It is not recommended that standard diesel fuel hose be utilised in this assembly. **When replacing or supplementing the kit provided – do not replace with standard grade diesel fuel hose, contact Astra for extra supplies.**

A total length of 300mm of high grade hose (HS0013 - special material specification) is incorporated within the standard kit. Generally this is supplied in the pre-cut lengths advised in Fig 2, and should be installed using the 'O' clips provided, ensuring that all crimps are properly secured. Part number HS006, the blue Ø6mm OD hose is provided to make up the balance of the suction hose length, and is inserted directly into the larger diameter hose, prior to securing with crimps. As the blue hose is Nylon material (for compatibility with the fuel borne catalyst), please take care not to allow kinks in the length of this hose. If preferred, this hose can also be further protected and disguised by threading it through flexible conduit.

3.4 Solenoid Pump.

When installing the solenoid pump (Pt No: EL0147), a "P" clip (Pt No: MC0113) is provided for securing the pump with a single M8 nut and bolt. As indicated in Fig 1, the pump should be installed as close to the injection point as possible. The pump MUST be installed horizontally. Please also be careful to note the arrow indicating direction of flow, which is stamped on the side of the pump body. Use the in-line additive filter provided (pt no: MC0117) again noting the flow direction indication. Mount to the suction side of the additive injection pump, securing with the crimp type or jubilee clips provided.

There is no polarity to the connections of the male plug, which is on the solenoid pump. A mating female connection is provided within the kit. The appropriate colour coded wires from the harness should be prepared and fitted with the white rubber seal, prior to crimping and then secured within the plastic housing from the rear – see fig 6, section 3.6.6

3.5 Fuel Borne Catalyst – Additive feed line from the pump.

Use only the specially selected compatible material supplied within the AdInject kit (Pt No: HOS0013 – 11mmOD / 5mm ID), provided for connection between the additive pump and fuel line injection point. Cut to a length of approx. 180mm. Length may be varied with custom applications, however it is recommended that the distance between pump and injection point is kept as short as possible. The hose is secured using crimp type 'O' rings (Pt No: MC0167) supplied and arranged generally as indicated in Figs 2 & 3 below.

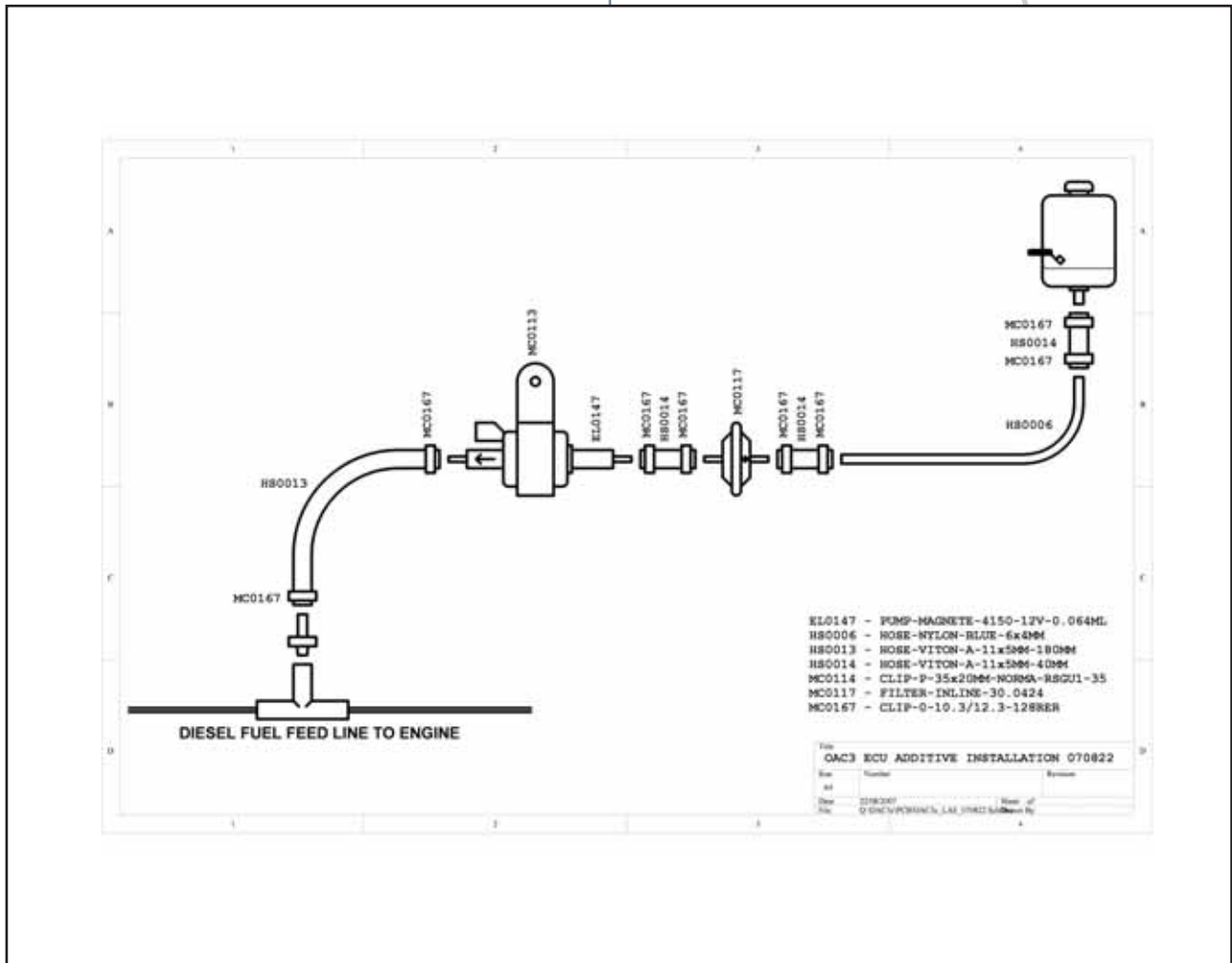

Fig 2 - Flexible pipe work connection diagram

A hose tail and 'T' piece assembly can be provided for the additive injection point. As fuel lines vary in diameter and material, either push fit, compression fittings or hose tails will need to be specified when ordering.

Important note: The injection point assembly should be inserted into the fuel feed line from the fuel tank to the engine.



Fig 3. Typical Injection point assembly arrangement

Prior to filling the additive tank with Fuel Borne Catalyst, it is recommended that full installation and commissioning of the electrical system is completed, prior to filling the system with additive. This will allow a filling routine for the additive tank which will verify operation of the level switch, as described later in section 5 - commissioning.

3.6 ECU – Dosing Controller (with Back Pressure monitoring).

3.6.1 Overview.

The dosing controller (Pt No: PX0275, fig 4.) is designed to control a solenoid driven injection pump, using system parameters of time and back pressure. The unit is housed in a rugged IP65 plastic enclosure with integral harness connector (Pt No PX0277). A dash-mounted indicator is provided for the driver/operator. Manual controls and serviceable control parameters can be accessed by a service interface lead connected between the ECU and a laptop computer via an RS232 port. A log of the previous 1024 hours of hourly based - back pressure, pump and alarm data can also be downloaded for analysis.

Fig 4. ECU Controller (Pt No: PX0275)



Fig 5. Typical Vehicle Installation.

3.6.2 ECU Installation

The ECU location is important and should be carefully considered prior to installation. Most often the location chosen for siting of the ECU is behind the dashboard (see fig 5). In either case, access across the top of the housing of the ECU should be available, to allow a magnet to be passed across the surface of the case (see figs 4/5). This action will be necessary during commissioning to initiate pump priming.

3.6.3 ECU Mounting

Secure the case using the mounting holes provided with the socket outlet facing downwards (requires M6 nut and bolts - see Section 8 – ECU technical specifications for dimensions). Locate in a position that is protected from potential mechanical damage but also allows engineers access to the top of the case as noted above. Location can be either external to the cab or mounted within the dashboard.

3.6.4 Back pressure connection

Flexible hoses (Pt Nos. HS005 – braided and HS0007 - PTFE) are provided in the kit to provide a two stage transition of pipe work from the filter silencer (DPF) to the ECU. This connection provides the facility to constantly monitor system back pressure. The ECU will trigger a warning to the operator should a high system back pressure condition occur.

The stainless steel flexible hose (Pt No: HS005) is used in the back pressure feedback system close to the filter where temperatures may be high. It comprises of a stainless steel over braided PTFE smooth bore hose with a Ø12mm compression joint at one end and " BSP female connection at the other. The Ø12mm compression joint is attached to the Ø12mm stand pipe located on the DPF inlet canister. A fitting (Pt No: MC0116) is provided to adapt from the stainless steel hose (HS005) to the translucent PTFE hose (HS0007).

It is recommended that routing of the hoses is identified and then loosely installed. Attention should be paid to locating positions at which the hose can be secured to either chassis or other suitable parts – such as vehicle looms. When satisfied with the routing, attach the hoses and secure with cable ties **ensuring that neither the stainless steel braided hose nor the PTFE hose is either kinked or compressed by the cable ties.** The PTFE hose (HOS006) can be trimmed to length. Place the knurled locking ring over the hose, push the hose over the hose tail and secure with the knurled screw locking ring. See fig 6

3.6.5 Wiring.

With the pre-wired grey coloured plug disconnected from the dosing controller (PX0275), locate and commence routing of the wiring harness cables to the other system components (level switch, pump, power supplies, etc).

With reference to the circuit hook up diagrams 1 & 2 (section 3.6.9), and utilising the colour coded wiring harness provided, make all the connections as indicated. Care must be taken to ensure that the cables are neatly secured to the vehicle with cable ties. It is strongly recommended that all wiring added to the vehicle as part of the AdInject dosing system is fully encapsulated in flexible conduit, complete with connector shrouds, using the materials provided..

When all wires are connected to the system components and the power supplies verified by testing with a multi-meter, plug the wiring harness into the ECU. NOTE : Polarity - It should be noted that there is no polarity to the wiring of either the level switch or the solenoid injection pump.

Please ensure that the grey coloured connection cover is utilised to protect the connection between the cable harness and the ECU. Ensure location of the ECU is selected in order to minimise the possibility of the ingress of water to this connection point.

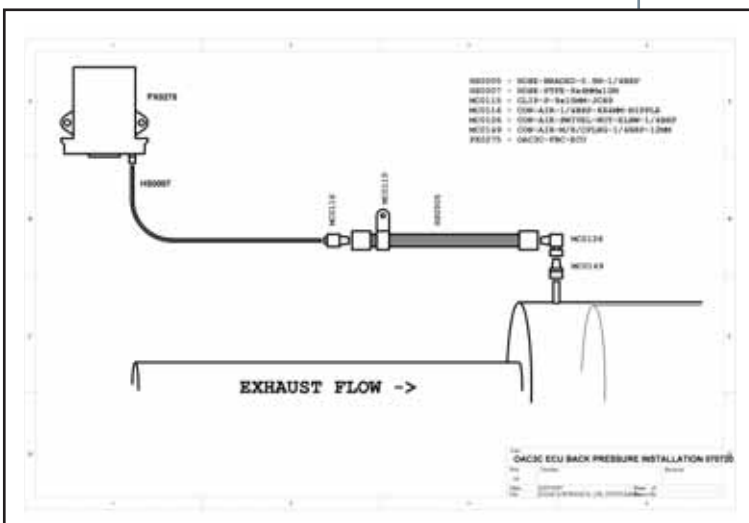

Fig 6 – back pressure connection

3.6.6 Electrical connection to solenoid injection pump

There is no polarity to the connections of the solenoid injection pump. A female socket connection kit is provided. Identify and prepare the colour coded wires of the cable harness. Fit the white rubber seals prior to securing the spade crimp connectors. Once the spade connectors are crimped, insert into the connector housing from the rear of the connector, ensuring that the spades are pushed fully home (see fig 7).



Fig 7. Pump electrical connector

3.6.7. Wiring to level switch

When connecting to the level switch it is possible to connect either wire without polarity as correction for indicating at low level will be made during commissioning. When the service interface lead is connected to a laptop via an RS232 port - a setting within CONTROL PARAMETERS allows the polarity of the switch to be set (see section 9)

3.6.8 Dashlamp Indicator

Location of the dash lamp indicator should be completed by an experienced auto electrician as access to the cabin dashboard area will be required. Carefully mount the lamp holder into the dashboard (see figs 8 & 9) utilising where possible a blank or unused switch holder. Drill the blanking plate to Ø16mm, in order to produce a neat flush mounted installation. The dashlamp indicator is diode type (no replaceable bulb). Screw terminals are provided, with indications for +ve and -ve connections.

At this point please also fit the dashlamp warning label – either close to the indicator or on the windscreen of the vehicle (see section 6.1)

Dash Indicator Fig 8



Typical Dash indicator installation Fig 9



3.6.9 Wiring - hook-up diagram 1

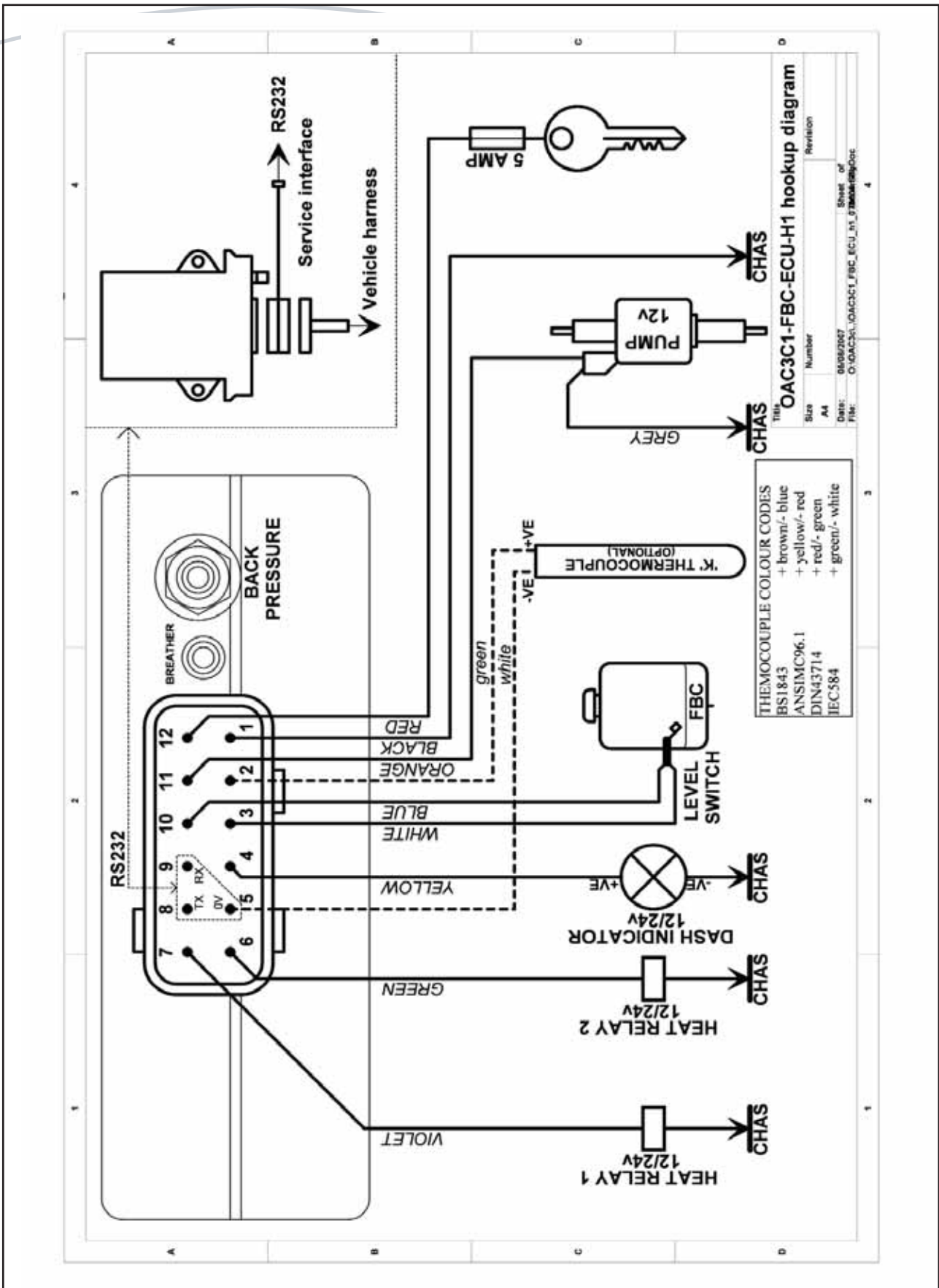

Adastra - Fuel Borne Catalyst Dosing System

Wiring hook up diagram 2

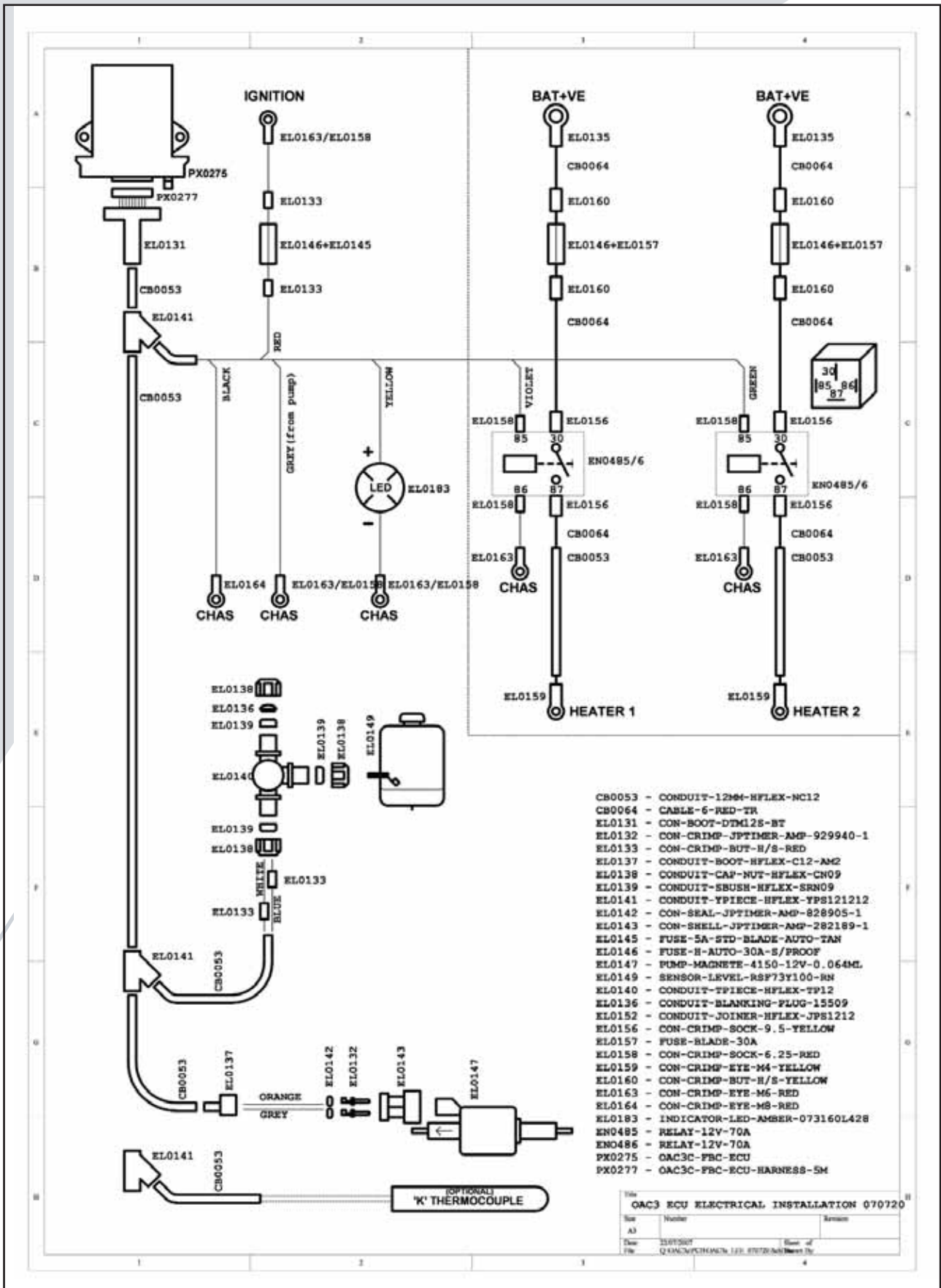

3.7 ECU – Service Interface

As indicated in the wiring - hook up diagram 1 (3.6.9) a lead is available to trained installation engineers which allows the engineer to interrogate and where necessary adjust the settings and control parameters of the AdInject ECU. As indicated in the hook up diagram – connection lead part number PX0304 (supplied only to trained installation engineers) inserts between the ECU and the cable harness to connect to the ECU and at the other end to an RS232 connection of a laptop computer. No special software is required. For further information see section 9.

3.8 Injection pump cycle time.

The pump runs at a predetermined rate dependent on several key factors: engine size, power, vehicle application and annual mileage. The dosing rate is set on commissioning by connection to the user interface.

During vehicle operation while the system operates normally below the MAX RUNNING PRESSURE set point the normal pump cycle rate will apply. However should the soot load in the filter become abnormally high the pump rate progressively increases to twice the normal cycle rate as the pressure increases above MAX RUNNING PRESSURE.

When the system is first run, or when a new filter element is fitted, the pump runs at 1.5 times normal cycle rate for a conditioning period, to prepare the internal surfaces of the fuel and exhaust system.

When enables the pressure check alarm function runs the pump at a fixed fail safe rate of 1.2 times normal cycle rate, when it detects there to be a fault in the back pressure monitoring system.

3.9 Priming

Priming of the pump is controlled either by placing a magnet close to the top left corner of the ECU (see fig 4) or from the diagnostic manual CONTROLS page – see section 9. Once started, the pump runs for 5 minutes or can be stopped / restarted by magnet or from the CONTROLS page.

Section 4 - Active regen system installation

4.1 Overview

The active regen system is designed to work in conjunction with an AdInject FBC dosing system ECU to aid regeneration of the filter where vehicles may require to be used frequently on low speed duty cycles (such as city centre operation), where low exhaust temperatures often occur. In these circumstances the active regeneration feature will help control back pressure and avoid blocking of the filter. The system is designed to be automatic, initiated and controlled by the Adinject ECU. Though standard from 2007 supplies, active regeneration can be added to earlier Adastra filter systems with replacement of the filter hardware, ECU and an additional electrical installation.

4.2 Installation

These instructions are based on the installer having already completed the installation of the Adastra filter system and AdInject dosing system as described in sections 1 – 3. Installation should be completed by a trained and competent auto electrician.

Prior to commencing installation position of the following components needs to be considered:-

- Location of the vehicle battery source (12V). This is required to power the glow plug heater elements. The relays and fuses need to be positioned close to the power source, to avoid excessive lengths of cable. A long cable will result in a large voltage drop which may prevent the glow plugs from reaching their optimal operating temperature.
- Location of the exhaust and an identification of a suitable route through the vehicle for power cables. Often the power cables can follow a similar route to the back pressure hose of the AdInject dosing system. Care must be taken to avoid hot pipe work and pinch points, whilst minimising the length of cable required.
- Location of a suitable earth connection. This should be as close to the filter as possible, thus ensuring that voltage drop is not significant. A mounting bolt of the filter cradle to the chassis is often a suitable point on many applications.

4.3 Relay connection

The relays need to be positioned close to the power source. A relay mounting box is provided (Fig 9). Figure 10 shows the wiring diagram for the relays. Before commencing installation check that the relays are the correct voltage rating for the electrical system. The active kit is supplied with for 12V relays dependent on specification at time of order, allowing for light duty to heavy duty installations. **DO NOT** connect a 12V relay to a 24V systems or visa versa.



Relay mounting box Fig 10

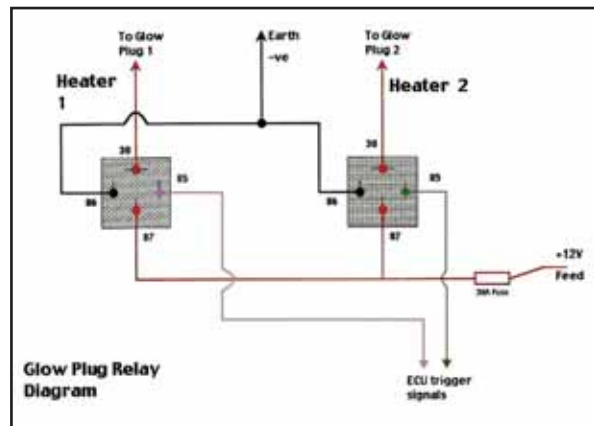

Relay wiring diagram Fig 11

Wiring hook up diagram 2 identifies the parts utilised in connecting the active regen system. The wires indicated in violet and green (hook up diagram 1 and Fig 11 above) are already part of the Adinject dosing system wiring harness and provide a link for control output of the active regen system – see wiring hook up diagram section 3.6.9.

The black earth wire needs to be 22AWG, excess wire from the AdInject wiring harness is usually available and can be used for this purpose.

Power cable (red) in 14AWG wire is utilised for connection of the 12V feed from the battery to the relay and from the relay to the glow plugs. This cable size has been specified to ensure that the voltage drop along the cables is not excessive and in order to maintain optimum glow plug operation.

It is recommended that the glow plugs should be wired in parallel circuits as this will ensure that in the unlikely event of the failure of one circuit, the other will continue to operate. The relays should be labelled 1 and 2 to denote which glow plug is connected to which relay.

4.4 Power cable routing

As previously discussed power and earth cabling to the glow plugs should be as short as possible. All cabling should be routed through the vehicle utilising the flexible conduit supplied within the kit. Conduit and cable should be neatly secured using the cable ties provided, avoiding hot pipe work and/or fouling existing vehicle systems.

4.5 Glow plug installation

The glow plugs (2) fit into the inlet flange of the Adastra filter. Figure 12 below shows a drawing of the filter with the glow plug positioning. The thread size is M10 x 1.5 – the system has been design and validated to accept only NGK (model: 4315CY03) high temperature plugs – available from Astra should spares be required. No other make or type of glow plug should be used as variance in the length and tip position could detrimentally affect operation of the active regeneration system.

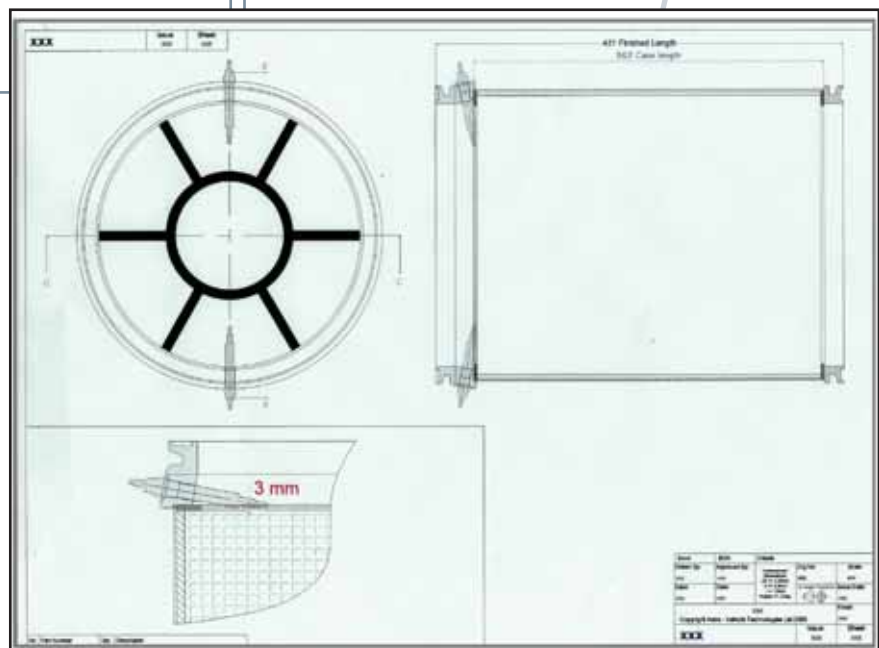

Filter diagram with glow plug inserts Fig 12

It is recommended that glow plug 1 is always installed on the nearside of the filter and glow plug 2 to the offside. This ensures that the wiring path is consistent and clear from vehicle to vehicle. Once the filter and glow plugs are installed on the vehicle, the cables from the relays should be attached to the glow plugs. See figs 13 & 14.



Glow plug wiring to relay box Fig 13



Battery supply wiring including 30 Amp fuse Fig 14

4.6 Active regen ECU settings

The AdInject dosing system ECU contains a unique algorithm to control the functionality of the system. The ECU should only be configured by an experienced installation engineer authorised by Astra. Tailoring for specific duty cycles can be accommodated. The ECU should not be tampered with by an operator, or other non-authorized personnel, as doing so will invalidate the warranty of the system.

Important Note: On commissioning an active regen system it will be necessary for an authorised engineer to adjust the default ECU settings, to switch on the heater function part of the programme.

Section 5 - Dosing system commissioning.

It is recommended that the electrical system is commissioned and a functional check made of normal operation, which includes the operation of the start up sequence of lights, before the additive tank is filled.

- Ensure the wiring connections are complete as indicated in the wiring – hook up diagram and that the loom is secured, by inserting the grey multi-wire plug into the ECU socket connection.
- Check that all flexible hose connections have been made (Fig 1) and that all crimp connections are completed and secure.
- Check all back pressure connections are secured and there are no kinks at any point between the filter and the ECU.
- Check power to the ECU and the level switch circuit. With the ignition ON and an empty additive tank, the dash light should illuminate for one second and then go out. The dash light should then proceed to an alarm condition – blinking four times on a repeating cycle to indicate low additive level
- Carefully fill the additive tank with Satacen (R) 3, from the bottles supplied. As the tank is filled the level alarm warning will cancel. Both dash lamp indicator and the LED warning in the ECU will cancel. This demonstrates that the low level alarm float switch is operational and functioning correctly.
- In some circumstances, dependent on the wiring – the low level alarm will not indicate an alarm. In this case as no additive has yet been added to the tank, polarity will have to be reset by reversing the blue and white wire connections of the wiring harness to the level switch or alternatively, by connecting the service interface lead to a laptop and following the instructions for resetting the polarity of the level switch. (see instructions – section 9)
- Having filled the additive tank check all flexible hose and tank outlet/fittings for any evidence of leaks.

- Prime the dosing system as described in section 3.9 preferably by use of a magnet passed across the right hand top corner of the ECU. This will operate the injection pump at a constant 1 stroke per second. The pump should be heard operating, and/or on touching the casing it will be possible to feel the pump operation. Priming will continue for a preset time of 5 minutes, however the priming function can be stopped/restarted by repeated action of the magnet until the additive can be seen to have filled the translucent additive filter and run approximately for a further 2/3 minutes. This will ensure that the additive system is fully primed for operation.
- Add a quantity of Satacen (R) 3 Fuel borne catalyst to the vehicle diesel tank in the approximate ratio of 0.5ml per litre of fuel in the tank. This helps with the conditioning of the engine and the DPF exhaust system.
- System commissioning is now complete and testing of the installation can be completed by running the engine. Please ensure that all normal operator checks are conducted prior to starting the engine, brakes are applied and the gearbox is in neutral.

Section 6 - Faults and Warnings.

The dash indicator (section 3.6.8 – figs 8 & 9) reports the system status to the driver/operator. At ignition ON, the dash lamp illuminates for a one second lamp test. If any alarm is subsequently results a series of blinks will occur signalling an alarm condition and cycling around each tripped alarms, in turn. Latched alarms can be cleared by turning the ignition OFF and back ON.

6.1 Summary table of fault conditions :

Dash lamp signal	Function or fault description	Action
Ignition switched on – lamp blinks on for 1 Sec	Start up system check – OK	None - this is normal.
Ignition switched on - lamp doesn't blink when ignition switched on	Start up system check – error	Call for service
Lamp ON & continuously illuminated	High back pressure alarm	System service required – call for service
All other fault conditions are indicated by a series of dash lamp blinks which repeat every 4 seconds and cycle through each fault		
4 blinks	A low level of fuel borne catalyst has occurred	Top up fuel borne catalyst tank. Refill only with Satacen 3 fuel borne catalyst
3 blinks	Pump circuit fault	Call for service
2 blinks	No Pressure alarm	Check back pressure hose for a leak or blockage. Ensure hose not kinked
1 blink	Ash alarm	Filter requires cleaning – call for service

6.2 High Pressure Alarm - lamp on continuously

The monitoring algorithm for the high pressure alarm is proprietary data unique to the Adastra filter system designed to maintain back pressure within the engine manufacturers guidelines. The high pressure alarm function monitors the accumulation of soot creating a high back pressure in the filter, above MAX RUNNING PRESSURE compared with time. The alarm trips when there has been an over pressure of MAX RUNNING PRESSURE for a PRESSURE ALARM RESPONSE period, or a scaling of these parameters.

6.3 Low additive level alarm

4 blinks low additive level alarm type - momentary

When the vehicle ignition is ON the level sensor monitors the fluid level in the FBC tank. An alarm is triggered when the level falls below the reed switch sensor. There is a certain amount of reserve capacity. However, when the alarm mode occurs it is advisable to refill the FBC container at the earliest opportunity, as operating the system without FBC could cause un-catalysed soot to accumulate in the filter and subsequent filter failure. Data log recordings can reveal abuse by operating the vehicle without FBC. Refill the FBC container only with Satacen® 3 fuel borne catalyst.

6.4 Pump fault alarm

3 blinks pump fault alarm type – latched

The controller monitors the integrity of the electrical connection to the pump. An alarm is triggered when the controller detects open or short circuit pump drive pulses, caused by a faulty wiring harness.

6.5 Pressure fault

2 blinks pressure fault alarm type - latched for 1 hour

When the PRESSURE CHECK ALARM function is enabled (control parameters), a fault is signalled when there is a lack of back pressure activity, suggesting that the back pressure pipe is either blocked or broken. Ice in the back pressure hose or a faulty or broken exhaust pipe can also cause this fault indication.

6.6 Ash alarm

1 blink ash alarm alarm type - latched for 1 hour

The ECU program contains a proprietary algorithm unique to the Adastra filter system which monitors historic back pressure data. The filter will regenerate and clear its soot collection automatically through either passive regeneration from the fuel borne catalyst or via the active regeneration heating elements.

When the ASH ALARM function is enabled (control parameters), an alarm is signalled when the back pressure has not dropped below the ASH MIN PRESSURE setting for the ASH ANALYSIS PERIOD

NOTE: wording in capitals indicate settings which can be adjusted by a trained Adastra installation engineer using the service interface lead connection to a laptop.

Section 7 - Operation & Maintenance

7.1 Operation

In normal varied duty cycles where there is a mix of high speed and low speed driving, also a mix of high and low load conditions; regeneration of the filter will occur without call for operation of the back up – "active" electrically heated part of the regen system. Fuel borne catalysed carbon (soot) collected in the high efficiency Silicon Carbide filter burns very easily with peaks of temperature, which will occur naturally from varying load and speed conditions. In low speed/low load driving cycles where infrequent excursions of high temperature occur, electrical heating via the glow plugs will be triggered to prompt a regeneration as a back up. There is generally no necessity to alter how or where one utilises the vehicle.

7.2 How to encourage a regeneration of the filter

If the vehicle duty cycle has been such that the filter has collected a volume of soot without regeneration (which may be indicated by a high pressure warning light), it may be possible to force a regeneration by following a particular driving pattern.

Before attempting to force a regeneration event, check function of the dosing system to verify that the filter has been receiving catalysed carbon (soot). Only catalysed soot can be encouraged to regenerate by the following process. Un-catalysed soot will be unlikely to regenerate and the filter should be exchanged. Only complete the following driving cycle on a suitable road and paying full attention to safe driving conditions.

- Being careful not to overdose, add Satacen 3 directly to the diesel fuel tank, in the estimated proportion 0.5ml per litre of diesel fuel.
- Drive cycle regeneration will be aided if a fully secured maximum payload is in place.
- Initially operate the engine to obtain optimum engine operating temperature
- Only once normal operating temperature has been reached, when safe to do so and within legal road speed limits, drive the engine hard but in a controlled manner in order to increase exhaust temperature. It may be necessary to drive along a dual carriageway or main road, at peak revs and/or governed speed for up to 10mins to achieve this condition.

- After a hard acceleration or prolonged running as described above, lift off the throttle and let the engine go on to over run. This action provides a surge of excess Oxygen in the gas stream and subsequently into the hot filter.
- The combination of hot filter, excess Oxygen and the fuel (catalysed carbon) within the filter will create the required conditions for regeneration (Combustion of the soot) and thus cleaning the filter.
- After decelerating carefully, pull over at a safe place to stop and let the engine idle for 2-3 minutes by which time regeneration should be complete.

To summarise:-

From a normal temperature engine condition – accelerate hard and maintain peak power and load. Back off and let the engine revs decline on over run. Pull over at a safe place and let the engine idle for 2-3 minutes. Only complete this process in appropriate road conditions and having checked operation of the dosing system.

If a high pressure warning persists – call for service, the filter will need to be exchanged and the dosing system serviced prior to further use.



Fig 15

7.3 Fuel borne catalyst top up

Use only Satacen® 3 fuel borne catalyst, which is available directly from Astra. FBC is supplied in easy to handle 2.5 litre plastic containers (see fig 15). The container fitted as part of the dosing system is translucent plastic (like a windscreen washer bottle) and the level of FBC will therefore be evident when completing other regular checks of consumable items on the vehicle. The dosing rate is very small, FBC being consumed at a rate of 1 litre per 2,200 litres of diesel fuel. Top ups are therefore relatively infrequent, and when calculating mileage against fuel consumption the user can roughly calculate the frequency of top ups required.

When topping up with Satacen® 3 FBC fill with care, directly from the plastic container. For the protection of the environment take care not to spill Satacen 3. When handling Satacen 3 use protective gloves, splash protection for clothes and safety glasses. A data sheet detailing the hazard level of the FBC material is included with this manual. Please note, filter system and vehicle performance may be impaired if either the FBC tank is allowed to run dry, or an alternative liquid is used.

7.4 Servicing the filter

All Adastra filter systems utilise a simple clamp ring and gasket assembly system which allows easy access for service, without the need to disassemble pipe work or remove the entire silencer. In certain installations heat shield straps may also support the filter installation. During disassembly take note of heat shield locations and support straps used for later reassembly and take extra care not to drop the filter unit when removing for service. Before commencing any service work, ensure a safe working area and that the exhaust system is cool enough to touch without burning.

Prior to removal of the filter it will be necessary to disconnect the electrical connections to the two glow plug heaters and carefully remove the glow plugs – see section 7.9

Once the glow plugs have been disconnected, the filter can be removed by releasing the two single bolt "V" clamps, one at either end of the filter section of the silencer. The filter unit is heavy - care should therefore be taken to adequately support the filter during its removal. Damage caused by dropping the filter will be chargeable.

The Adastra filter clamp system is uni-directional, due to the glow plug heating elements inserted into the inlet end of the filter. Reversal of the filter should not be attempted, as it will not be possible to reconnect the glow plug heating system. Ash accumulated within the filter should be removed by professional cleaning.

Replacement of a filter is the reverse to the above process. When replacing a filter check first the condition of the gaskets and if necessary replace with the new gaskets supplied with the service exchange filter unit. Prior to refitting glow plugs ensure first that they are in good condition – per the guidance in section 7.9

7.5 Filter inspection

Filters that have been removed for inspection should be handled with care using appropriate personal protection equipment. Astra recommend the use of protective safety glasses and gloves as a minimum, together with the use of safety shoes.

Taking care not to damage the inlet and outlet flanges of the filter, a visual inspection of the inlet and outlet faces of the filter should indicate a clear difference in colour between the two end faces. The inlet face of the filter will be coated with soot, although the channels should not be totally plugged. If plugging exists the filter should be returned to Astra or its authorised and recommended sub contractor, for cleaning.

The outlet face and channels of the filter should not be plugged with soot and should be relatively clean, without significant deposits or traces of soot. Significant deposits of soot on the outlet face or around the circumference of the filter outlet face indicate a possible problem with the mechanical integrity of the filter and thus reduced filtering efficiency. In this case the filter should be returned to Astra for examination.

7.6 Adastra Filter - service exchange

Filter cleaning and the removal of accumulated ash can only be achieved with specialist cleaning equipment. It is strongly recommended therefore that an Astra service exchange filter is used on a regular basis and at least once per 60,000Km or annually (whichever sooner). A service exchange filter unit can be arranged as a direct supply to an operators workshop or servicing agent. Alternatively an on-site fitting service can be provided by an approved Adastra filter service agent. All service exchange service units provided directly by Astra carry a 12 month guarantee.

Following installation of a service exchange filter, the commissioning engineer should adjust the conditioning timer reset (item p) in CONTROL PARAMETERS – see section 9.2

The Astra service exchange programme minimises vehicle downtime, whilst providing a safe and environmentally responsible means of managing waste disposal. A specially developed two stage cleaning process is applied to all Astra service exchange filters, initially baking the filter to remove unburned carbon, prior to a vacuum and high pressure air cleaning of the filter channels. High pressure washing of an Astra filter is not recommended.

7.7 Visual inspection of exhaust pipe work

Adastra filter system installations are manufactured utilising stainless steel pipe work and filter housings and therefore are generally long lasting and durable. Nevertheless, it is recommended that whenever the exhaust system is being worked upon during normal servicing, a visual inspection of the pipe work integrity is completed. Many Adastra filter installations incorporate a length of stainless steel flexible pipe retained between lap joint flex clamps. These sections are incorporated to isolate the transfer of engine vibration to the filter system. Flexible pipe in the exhaust system is considered to be a normal wearing item and will need to be replaced from time to time.

Check clamp joints in pipe work for tightness, a small amount of leakage is normal and acceptable in metal to metal joints. If however the flexible pipe is split or leaking, the component will need to be replaced. This can be achieved by first removing the lap joint clamps from either end of the flexible pipe section.

A replacement kit containing the flex pipe section and two clamps, can be obtained directly from Astra, by quoting the kit part number and serial number found on the nameplate. Flex pipes should be set to halfway between the compressed and extended length, prior to installation. See fig 16.



Fig 16 – typical flex pipe installation

7.8 Typical service intervals

During normal vehicle operation, the Adastra filter system maintenance requirements depend upon the rate at which soot and ash accumulate in the filter. The ash deposits are the incombustible residues of burnt engine oil, soot and catalyst and mineral in characteristic. As ash levels rise in the filter the capacity for soot storage is reduced and the back pressure of the exhaust system will rise more frequently. The dash lamp indicator of the Adastra system will indicate when the filter system needs servicing. In addition, periodic filter cleaning is recommended to maintain service intervals and system performance. The table below summarises the service type required and typical interval period for common vehicle categories.

Typical service interval guidelines:

Vehicle	Duty cycle	Approx. Annual usage in Km	Service every 4-6 months	Service every 12 months
London Taxi	Mainly low speed city centre operation	30,000 – 50,000	A, B, C, D	A,B,C,D,E
Light Van, minibus 1200–3500 Kg GWW	Varied use from city centre to long distance	30,000 – 60,000	A, B, C, D	A,B,C,D,E
Light truck, 3500-7500 Kg GWW	Varied use from city centre to long distance	50,000 – 80,000	A, B, C, D	A,B,C,D,E
Medium truck 7500-26000Kg GWW	Varied use from city centre to long distance	50,000 – 80,000	A, B, C, D	A,B,C,D,E
Heavy truck 28000 – 44000Kg GWW	Long distance haulage	80,000 – 100,000	A, B, C, D	A,B,C,D,E
Refuse collection vehicles	Local operation. Mainly very low speed and sustained idling	15,000 – 30,000	A, B, C, D	A,B,C,D,E
Single & double deck buses	City centre operation. Mainly low speed with periods of higher speed operation	30,000 – 60,000	A, B, C, D	A,B,C,D,E
Coaches	Mixed city centre, urban and long distance operation	30,000 – 80,000	A, B, C, DA	A,B,C,D,E
Fire appliances	Local operation. Varied duty cycle, idle, low load operations with sustained high power and load over short durations	10,000 – 15,000	A, B, C, D	A,B,C,D,E

Key: -

A – Smoke check

B – Visual inspection of exhaust system

C – Check FBC level and refill

D – Functional check of dosing system and alarms

E – Remove Adastra Sic Filter for cleaning and replace with service exchange unit

7.9 Active Regen Maintenance

The active regen system controls can only be serviced by authorized personnel. However, the operator can check the glow plugs and wiring for signs of wear, as follows:-

- Turn off ignition. Please be aware that glow plugs operate at high current, so it is necessary that all normal electrical safety precautions are observed. If in any doubt about the following instructions, please consult Astra.
- Remove power connection from glow plug.
- Remove plug from filter
- Check plug for excess wear noting the guidance instructions of the following picture



Fig 17 – glow plug

Tip length:-

- 0 – 2 mm = worn out, replace glow plug
- >2 – 8mm = OK, good condition

Typically the ceramic tip of the glow plug should be 3 – 8mm long when in good condition (see Fig 17). If the tip is shorter than this the glow plug will not work or will not initiate a regen and needs to be replaced. The glow plugs are considered to be a wear part and will need to be replaced from time to time.

- If replacing, use only the glow plug type recommended by and available from Astra (GKN) ensuring that the wiring is reconnected and securely fastened.
- Always check the integrity of cabling connected to the glow plugs for wear or damage.

7.10 Operational conditions for an Adastra filter and AdInject FBC dosing system

The Adastra filter system depends upon the continuous use of Satacen[®] 3 - fuel borne catalyst to aid regeneration of the filter. The system is not design to work with any other fuel borne catalyst or additive and must not be confused with other commercially available additives for exhaust systems such as Adblue. Use of an incorrect additive or other fuel borne catalyst, poor vehicle maintenance and excessive engine oil consumption can prevent the Adastra filter system and adInject dosing system from functioning satisfactorily and may lead to invalidation of the manufacturers warranty. Under no circumstances should the vehicle be operated without Satacen[®] 3 – fuel borne catalyst. The vehicle and the filter must be serviced according to the manufacturers recommendations in order to maintain optimal engine and exhaust smoke results. Failure to maintain both engine and exhaust filter system may lead to premature failures during annual VOSA tests.

7.11 Satacen[®] 3 fuel borne catalyst

Satacen[®] 3 is an iron based organometallic compound fuel borne catalyst developed by Innospec Specialty Chemicals Inc, a global manufacturer of petrochemical additives for fuels and oils. Without the Satacen[®] 3 fuel borne catalyst the Adastra filter system will not function correctly as excessive un-catalysed soot particles will rapidly build up within the filter which cannot be combusted. This may have an adverse effect on fuel consumption and over prolonged periods could cause damage to engine components.

- Satacen[®] 3 is available from Astra in 2.5 litre containers.
- Only Satacen[®] 3 fuel borne catalyst should be used within the Adastra filter system.
- A vehicle fitted with an Adastra filter should not be driven if the FBC container is allowed to run dry.
- The FBC system will require re-priming if the FBC container is allowed to run dry or the AdInject dosing system is repaired or replaced.

7.12 Fuel Specifications

The Adastra filter system is fuel sulphur tolerant and its use does not require Ultra low sulphur diesel fuel. However, do not use fuel additives other than those already incorporated in commercially available diesel fuel.

In addition to commercial available EN590 diesel fuel, the following bio diesel fuels are approved for use with an Adastra filter system utilising Satacen[®] 3 fuel borne catalyst:

- Greenergy global diesel – 5% bio diesel : 95% ULSD
- Global Commodities Uk Ltd – DriveEco
- Rix Biodiesel Ltd – Bioblend 5
- Petroplus Marketing Ltd – Bio-plus

7.13 Smoke levels

The levels of smoke achieved by the engine prior to fitment of an Adastra filter should not exceed the maximum limits set by the engine manufacturer or an upper limit of 1.5 m⁻¹. Higher engine out smoke levels would indicate that the engine is worn and/or poorly maintained. Astra reserve the right to decline to install an Adastra filter to engines considered to be unsuitable.

Post filtration smoke levels of a well maintained engine with a functioning filter should not exceed a maximum smoke reading of 0.2 m⁻¹.

7.14 Engine Oil

Low ash lubricants are recommended to maintain filter service intervals and optimal Adastra filter system performance

β Ensure engine oil consumption is within the engine manufacturers limits, typically less than 1 litre per 1,000Km.

During normal operation – ash will gradually build up within the filter. This is removed by regular service exchange of the filter (once per annum or 60,000Km which ever earlier)

Section 8 - ECU Technical Specifications.

Case:-

IP65 thermoplastic (Nylon 66), 134 mm x 118 mm x 36 mm

2 x Ø7.2 mm mounting holes, 102 mm apart, the box should be mounted with the connector facing downwards

Supply (ignition):- 12/24 VDC

internal auto reset, 6A trip, 3A hold, external fuse to include total current supplied by FBC-ECU

Inputs:-

Level,

from the float switch in the additive tank,

volt free single pole contacts

Temperature (optional)

'K' type thermocouple

Outputs:-

Dash indicator

at vehicle supply voltage, short circuit protected, nominal 1.8 Amp, trip at 5 Amp

Dosing pump, external 12v at 40 msec drive pulse, short circuit protected, nominal 1.8

Amp, trip at 5 Amp. Pump fault sensed as open/shorted loads

Heating device control relay drive at vehicle supply voltage short circuit protected, nominal 1.8 Amp, trip at 5 Amp

Dosing pump, external

Thomas Magnete 4150 pump

volume per stroke = 0.0635 ml

max suction pressure = -20 to +30 KPA (2m lift, to 3m drop from tank)

max delivery pressure = +20 KPA

Inlet/outlet ports:-

SMC 'M-5H-6' hose nipple for 6/4mm plastic pipe

RS232 serial port:-

Connection:-

Service interface = 9 pin 'D' connector

Bits per second = 9600

Data bits = 8

Parity = none

Stop bits = 1

Flow control = Xon/off

HyperTerminal Settings

Function keys =Terminal keys

Emulation =ANSI

Harness:-

pre assembled connector with 5 m cables

see hook-up diagram for wire colours and designations

Section 9 – Diagnostics and ECU settings – via service interface

When the service interface is connected between the FBC-ECU and the vehicle harness, the RS232 serial port enables the engineer's computer to access current running data, and diagnostic pages for manual **CONTROLS** and control **PARAMETERS** setting.

The computer should be running a terminal emulator program such as Windows 'Hyper Terminal', with a serial port set to 9600 baud, 8 bit data, no parity, 1 stop, and Xon/Xoff flow control.

Current running data is sent every second, of pressure and hourly peak pressure in KPA, and the number of pump strokes in that second. The status of the heat cycle is also repeated as 'T' when **HEAT HIGH PRESSURE TRIP** has been registered, 'H' when the heater is ON for **HEAT ON TIME**, and 'I' when a new heat cycle is inhibited for the remainder of the current **HEAT CYCLE TIME**.

----->	= current pressure (KPA)
----->	= hourly peak pressure (KPA)
----->	= current temperature (DegC)
----->	= hourly peak temperature (DegC)
----->	= pump strokes in previous second
--> T	= heat cycle Tripped
--> H1	= Heater 1 on
--> H2	= Heater 2 on
--> I	= next heat cycle Inhibited

"000,000,0000,0000,000,XN"

The diagnostic function is accessed at any time with the computer's 'F4' key, which then changes diagnostic pages. The ESC key is used to return to normal display, or back to the current diagnostic page if an error is made in data entry. Normal operation is resumed when no keys are pressed in 67 seconds.

9.1 Manual CONTROLS

```

CONTROLS          F4=>PARAMETERS  Esc=>EXIT
=====
a -DUMP DATA.....
b -PRIME.....      = on/off
c -HEAT 1.....    = on/off
d -HEAT 2.....    = on/off
    
```

'a' -will send logged data in CSV format to the host computer:-

```

|----->  `Mean KPA` pressure in hour      0-127
| |----->  `Peak KPA` pressure in hour     0-127
| | |----->  `Mean DegC` temperature in hour 0-1020
| | | |----->  `Peak DegC` temperature in hour 0-1020
| | | | |----->  number of pump `Strokes` in hour 0-9999
| | | | | |----->  above `ash` min pressure for hour 1=on
| | | | | | |----->  `pressure fault` in hour      2=on
| | | | | | | |----->  `pump fault` in hour        3=on
| | | | | | | | |----->  `low additive` level in hour    4=on
| | | | | | | | |----->  `over pressure` alarm in hour    5=on
| | | | | | | | | |----->  `heat` cycle in hour        6=on
    
```

"000,000,0000,0000,0000,7,7,7,7,7,7"

This file can be loaded into a spread sheet program such as Microsoft Excel for analysis, and a standard chart can be generated with a suitable macro for presentation. Each of the 1024 lines represents 1 hour of data. Pressures and pump rate can be plotted against Y1 as lines and/or columns, and flags against Y2 as a scatter diagram of events. If Y2 is scaled -20 to 6.5 value, the flags will be located at the top of the chart, and the 'ok' flags will be hidden above the chart.

'b' -will start/stop the pump priming function

'c'/'d' -will toggle heat controls, when enabled in diagnostic control PARAMETERS

9.2 Control PARAMETERS

```

PARAMETERS      F4=>CONTROLS   Esc=>EXIT
=====
a -PUMP NORMAL CYCLE.....sec = 45
b -CONDITIONING PERIOD.....hr = 60
c -MAXIMUM RUNNING PRESSURE...kpa = 20
d -PRESSURE ALARM RESPONSE.16secs = 19
e -ASH MIN PRESSURE.....kpa = 10
f -ASH ANALYSIS PERIOD.....hr = 60
g -HEAT HIGH TRIP PRESSURE...kpa = 30
h -HEAT LOW TRIP PRESSURE....kpa = 10
i -HEAT ON TIME.....sec = 30
j -HEAT CYCLE TIME.....min = 20
k -ASH ALARM..... = on
l -PRESSURE CHECK ALARM..... = on
m -LEVEL SENSOR INVERT..... = off
n -HEAT FUNCTION (off/one/two)... = off
o -SERVICE CODE..... = F4
p -RESET CONDITIONING TIMER..... ( 0)
q -RESET TO DEFAULT VALUES..... ( )
    
```

When a line letter is entered, an arrow is placed at the end of that line to confirm the selection, then for:-

'a' to 'j' -numeric parameters, up to three numbers are entered and repeated on the screen after the arrow. The final value is then confirmed with the Ent key, and a new screen with the new value is displayed. If the entered value is out of range, the new displayed value will be corrected.

'k' to 'n' -control functions, status is toggled by the Ent key, and a new screen with the new status is displayed.

'o' -service code, three letters are entered and repeated on the screen after the arrow, upper and lower case letters may be used only. The final code is then confirmed with the Ent key, and a new screen with the new code is displayed. If **XXX** is entered, the service code is cleared back to the default 'F4'.

'p' -reset conditioning period, the Ent key resets the conditioning period, and a new screen is displayed with the conditioning period hours in brackets returning to 0.

'q' -reset to default values, the Ent key returns all parameters back to default values, a new screen is displayed with **RST** in brackets.

9.3 Service Code

By default, F4 is used to access control **PARAMETERS** from the manual **CONTROLS** page. However, to stop unauthorised access to these parameters, a service code can be set up in control **PARAMETERS** that is specific to the FBC-ECU. The 3 upper/lower case letter code will then be asked for every time the control **PARAMETERS** page is accessed.

Should the code be forgotten, an encryption of the code is available in the first line of the factory test mode. This can be relayed back to the FBC-ECU manufacturer for decrypting.

9.4 Factory test mode

The FBC-ECU is put into factory test mode by entering 't' while in the manual **CONTROLS** page, and returns to normal operation when ESC is entered or when no keys are pressed for 512 seconds.

The first line repeats specific data for the FBC-ECU:-

```
|-----> encoded service code data
| |-----> reserve supply value
| | |--> log status
"Abc-000-000"
```

The computer then shows a line of data every _ second:-

```
|-----> level sensor           \.'=O/C \#'=C/C
| |-----> pump drive status     \.'=ok \#'=fault
| | |-----> prime switch        \.'=O/C \#'=C/C
| | | |-----> pressure sensor    0-1023, 8 per KPA
| | | | |-----> temperature input 0-1023, 1 per DegC
| | | | | |<----- 1 = A2 Analogue supply 1/2 sec off
| | | | | |<----- 2 = heat drive 1    1/2 sec on
| | | | | |<----- 3 = heat drive 2    1/2 sec on
| | | | | |<----- 4 = pump           1/2 sec on
| | | | | |<----- 5 = dash indicator  1/2 sec on
| | | | | |<----- 6 = local green     1/2 sec on
| | | | | |<----- 7 = local red      1/2 sec on
| | | | | |<----- f = clear logged data in FLASH
| | | | | |<----- e = clear essential data in EEPROM
| | | | | | |--> program signature
"- - - 0000 0000 n <OAC3Cm_7177"
```

**Section 10 -
Satacen (R) 3 – Hazard Safety Data Sheet.**

Follows on next page...

ASTRA

VEHICLE TECHNOLOGIES LTD

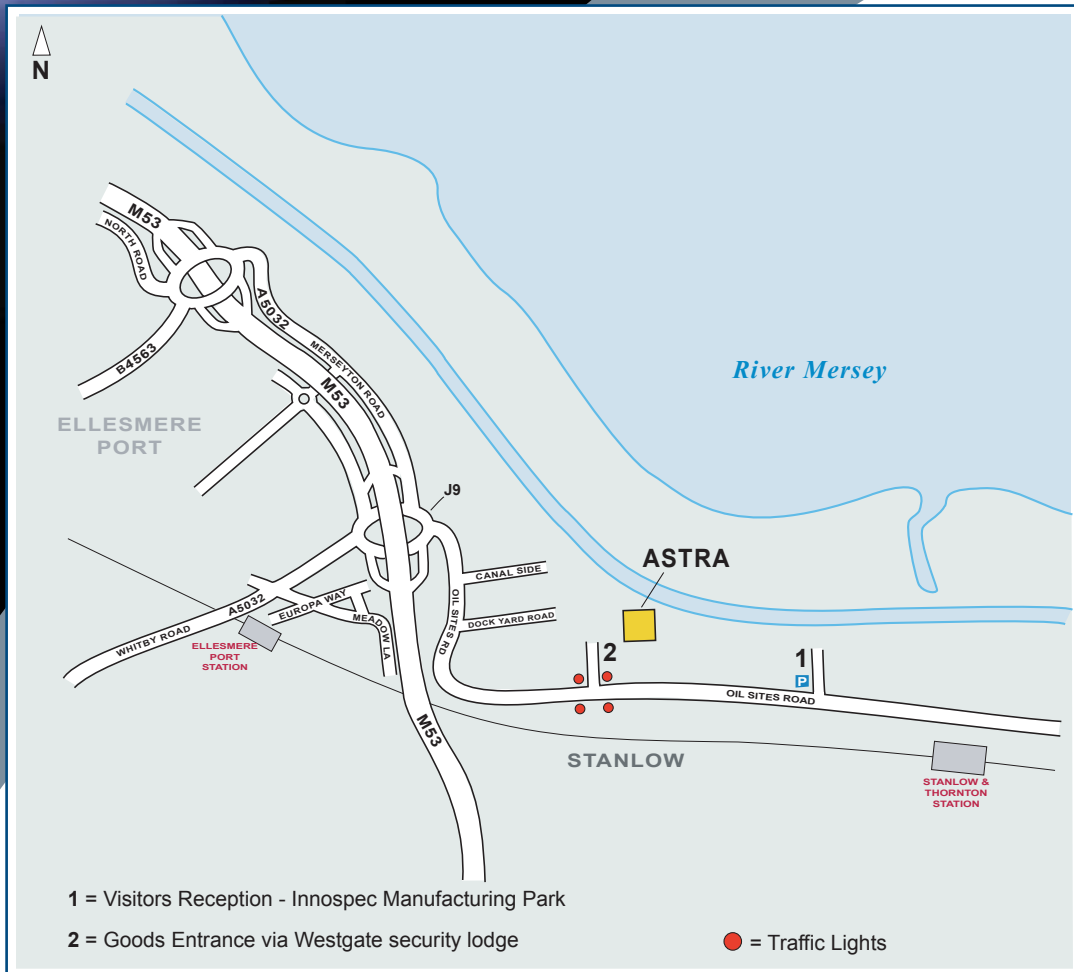

Astra Vehicle Technologies Ltd

Innospec Manufacturing Park,
Oil Sites Rd, Ellesmere Port, Cheshire
CH65 4EY, UK

Phone: 0151 348 5777
Fax: 0151 348 5778
e-mail: sales@astra-vt.com
www.astra-vt.com



adinject™